

## LM381/LM381A Low Noise Dual Preamplifier

### General Description

The LM381/LM381A is a dual preamplifier for the amplification of low level signals in applications requiring optimum noise performance. Each of the two amplifiers is completely independent, with individual internal power supply decoupler-regulator, providing 120 dB supply rejection and 60 dB channel separation. Other outstanding features include high gain (112 dB), large output voltage swing ( $V_{CC} - 2V$ ) p-p, and wide power bandwidth (75 kHz, 20 Vp-p). The LM381/LM381A operates from a single supply across the wide range of 9V to 40V.

Either differential input or single ended input configurations may be selected. The amplifier is internally compensated with the provision for additional external compensation for narrow band applications. For additional information see AN-64, AN-104.

### Features

- Low noise — 0.5  $\mu V$  total input noise
- High gain — 112 dB open loop
- Single supply operation
- Wide supply range 9V–40V
- Power supply rejection — 120 dB
- Large output voltage swing ( $V_{CC} - 2V$ )p-p
- Wide bandwidth 15 MHz unity gain
- Power bandwidth 75 kHz, 20 Vp-p
- Internally compensated
- Short circuit protected

### Schematic Diagram

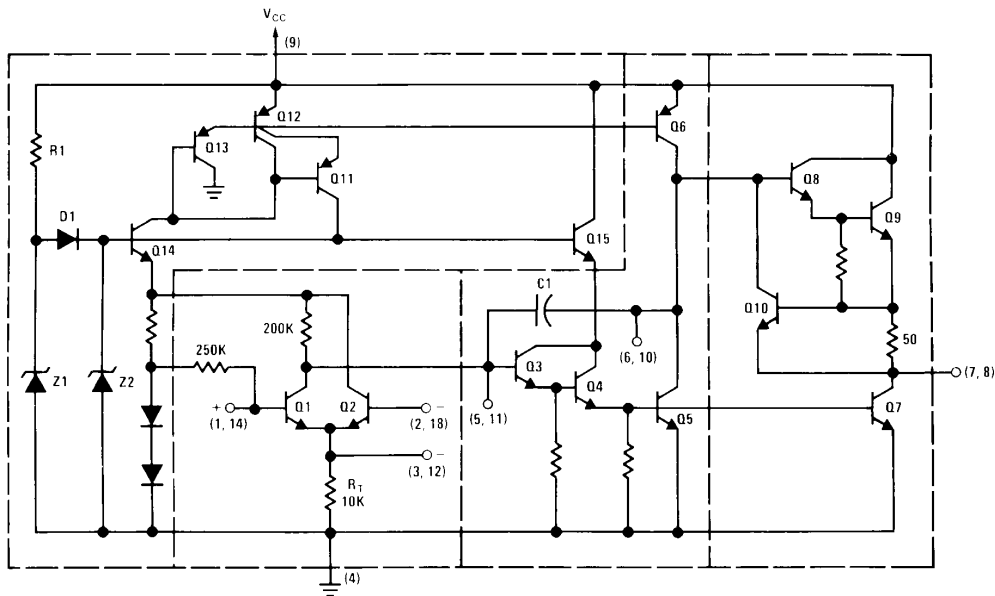

TL/H/7841-1

## Absolute Maximum Ratings

If Military/Aerospace specified devices are required, please contact the National Semiconductor Sales Office/Distributors for availability and specifications.

Supply Voltage +40V  
Power Dissipation (Note 1) 1.56 W

Operating Temperature Range 0°C to +70°C  
Storage Temperature Range -65°C to +150°C  
Lead Temperature (Soldering, 10 sec.) 260°C

## Electrical Characteristics $T_A = 25^\circ\text{C}$ , $V_{CC} = 14\text{V}$ , unless otherwise stated.

Parameter	Conditions	Min	Typ	Max	Units
Voltage Gain	Open Loop (Differential Input), $f = 100\text{ Hz}$		160,000		V/V
	Open Loop (Single Ended), $f = 100\text{ Hz}$		320,000		V/V
Supply Current	$V_{CC} 9\text{V to }40\text{V}$ , $R_L = \infty$		10		mA
Input Resistance (Positive Input) (Negative Input)			100		k $\Omega$
			200		k $\Omega$
Input Current (Negative Input)			0.5		$\mu\text{A}$
Output Resistance	Open Loop		150		$\Omega$
Output Current	Source		8		mA
	Sink		2		mA
Output Voltage Swing	Peak-to-Peak		$V_{CC} - 2$		V
Unity Gain Bandwidth			15		MHz
Power Bandwidth	$20 V_{PP}$ ( $V_{CC} = 24\text{V}$ )		75		kHz
Maximum Input Voltage	Linear Operation			300	mVrms
Supply Rejection Ratio	$f = 1\text{ kHz}$		120		dB
Channel Separation	$f = 1\text{ kHz}$		60		dB
Total Harmonic Distortion	60 dB Gain, $f = 1\text{ kHz}$		0.1		%
Total Equivalent Input Noise LM381A LM381	$R_S = 60\Omega$ , 10–10,000 Hz (Single Ended Input, Flat Gain Circuit, $A_v = 1000$ )		0.5	0.7	$\mu\text{Vrms}$
			0.5	1.0	$\mu\text{Vrms}$

**Note 1:** For operation in ambient temperatures above 25°C, the device must be derated based on a 150°C maximum junction temperature and a thermal resistance of 80°C/W junction to ambient.

## Connection Diagram

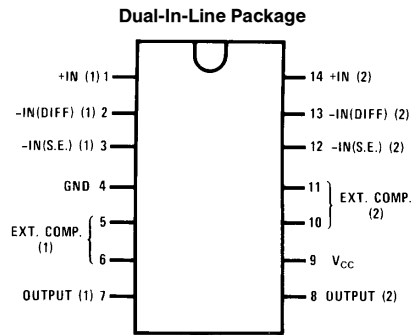

TL/H/7841-2

**Order Number LM381N or LM381AN**  
**See NS Package Number N14A**

## Typical Applications

Typical Tape Playback Amplifier

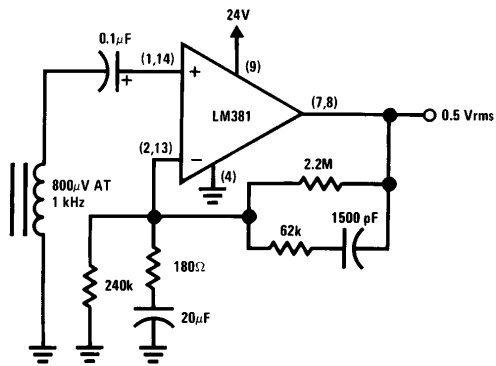

TL/H/7841-3

Typical Magnetic Phono Preamp

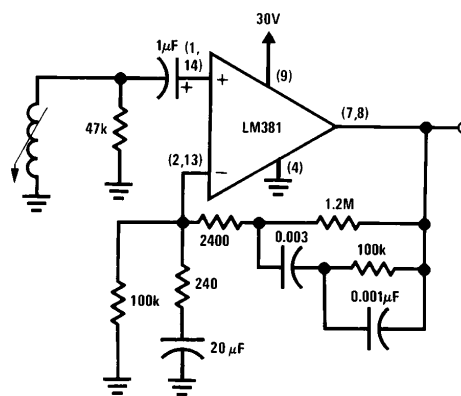

TL/H/7841-4

Two-Pole Fast Turn-On NAB Tape Preamp

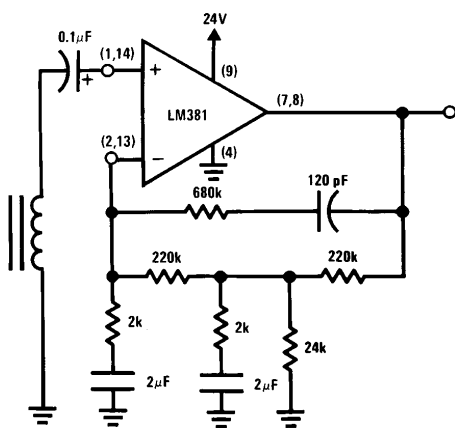

TL/H/7841-5

Audio Mixer

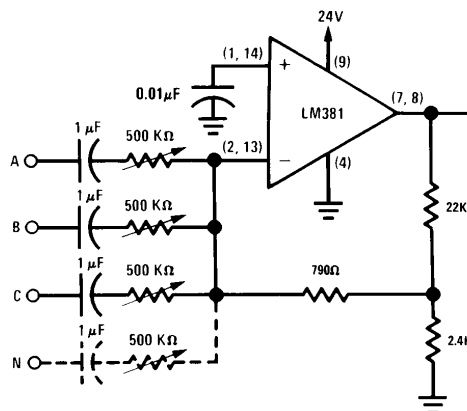

TL/H/7841-6

Ultra-Low Distortion Amplifier  
( $A_V = 10$ , THD < 0.05%,  $V_{OUT} = 3 V_{RMS}$ )

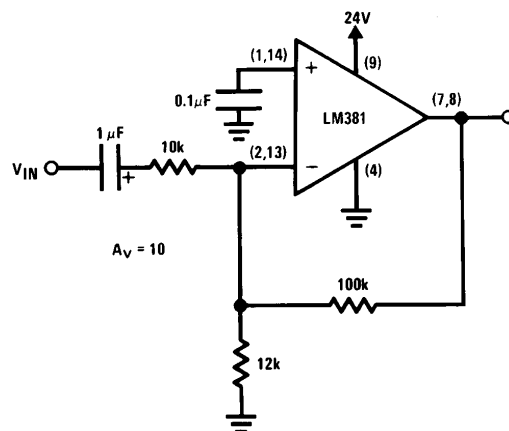

TL/H/7841-7

# Typical Performance Characteristics

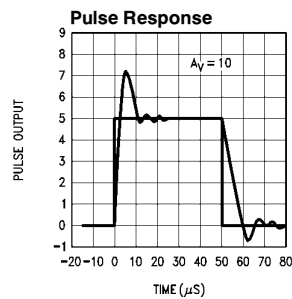
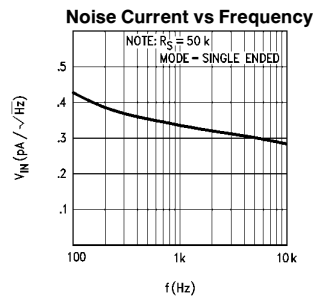
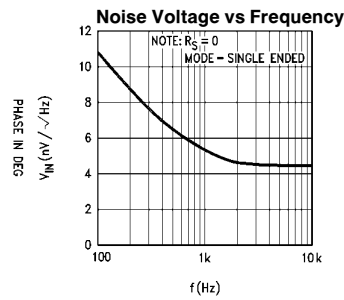
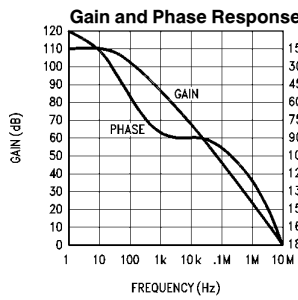
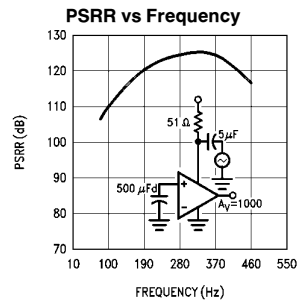
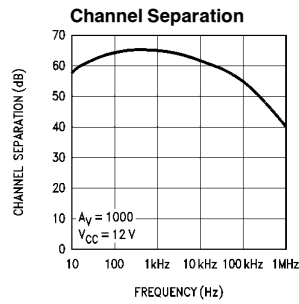
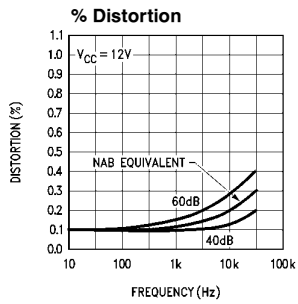
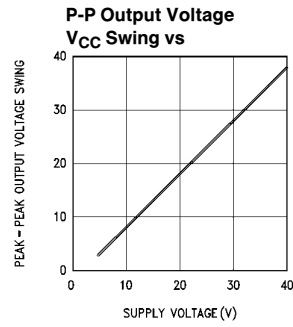
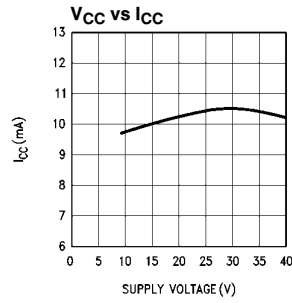
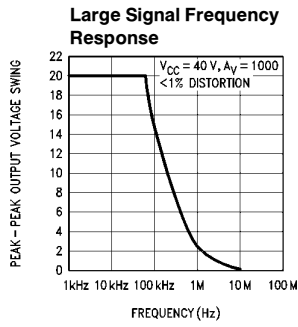

TL/H/7841-8



**Physical Dimensions** inches (millimeters)

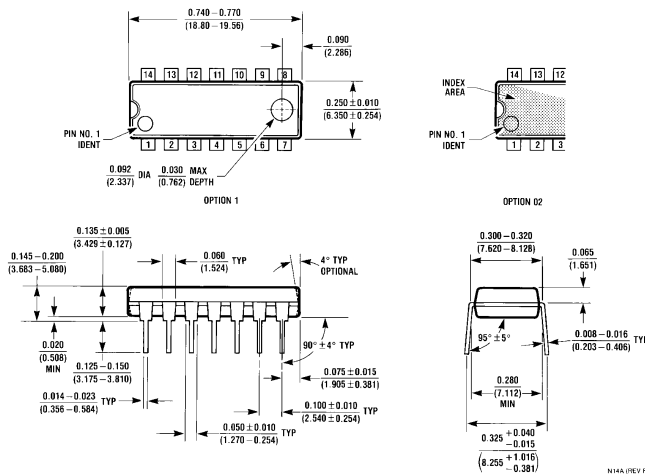

**Molded Dual-In-Line Package (N)**  
**Order Number LM381N or LM381AN**  
**NS Package Number N14A**

N14A (REV F)

**LIFE SUPPORT POLICY**

NATIONAL'S PRODUCTS ARE NOT AUTHORIZED FOR USE AS CRITICAL COMPONENTS IN LIFE SUPPORT DEVICES OR SYSTEMS WITHOUT THE EXPRESS WRITTEN APPROVAL OF THE PRESIDENT OF NATIONAL SEMICONDUCTOR CORPORATION. As used herein:

1. Life support devices or systems are devices or systems which, (a) are intended for surgical implant into the body, or (b) support or sustain life, and whose failure to perform, when properly used in accordance with instructions for use provided in the labeling, can be reasonably expected to result in a significant injury to the user.
2. A critical component is any component of a life support device or system whose failure to perform can be reasonably expected to cause the failure of the life support device or system, or to affect its safety or effectiveness.



**National Semiconductor Corporation**  
 1111 West Bardin Road  
 Arlington, TX 76017  
 Tel: 1(800) 272-9959  
 Fax: 1(800) 737-7018

**National Semiconductor Europe**  
 Fax: (+49) 0-180-530 85 86  
 Email: cnjwge@tevm2.nsc.com  
 Deutsch Tel: (+49) 0-180-530 85 85  
 English Tel: (+49) 0-180-532 78 32  
 Français Tel: (+49) 0-180-532 93 58  
 Italiano Tel: (+49) 0-180-534 16 80

**National Semiconductor Hong Kong Ltd.**  
 19th Floor, Straight Block,  
 Ocean Centre, 5 Canton Rd.  
 Tsimshatsui, Kowloon  
 Hong Kong  
 Tel: (852) 2737-1600  
 Fax: (852) 2736-9960

**National Semiconductor Japan Ltd.**  
 Tel: 81-043-299-2309  
 Fax: 81-043-299-2408

National does not assume any responsibility for use of any circuitry described, no circuit patent licenses are implied and National reserves the right at any time without notice to change said circuitry and specifications.

This datasheet has been download from:

[www.datasheetcatalog.com](http://www.datasheetcatalog.com)

Datasheets for electronics components.