

HA17741/PS

General-Purpose Operational Amplifier
(Frequency Compensated)

HITACHI

Description

The HA17741/PS is an internal phase compensation high-performance operational amplifier, that is appropriate for use in a wide range of applications in the test and control fields.

Features

- High voltage gain : 106 dB (Typ)
- Wide output amplitude : ± 13 V (Typ) (at $R_L \geq 2$ k Ω)
- Shorted output protection
- Adjustable offset voltage
- Internal phase compensation

Ordering Information

Application	Type No.	Package
Industrial use	HA17741PS	DP-8
Commercial use	HA17741	

Pin Arrangement

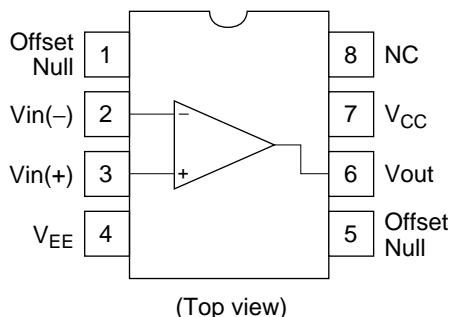

Circuit Structure

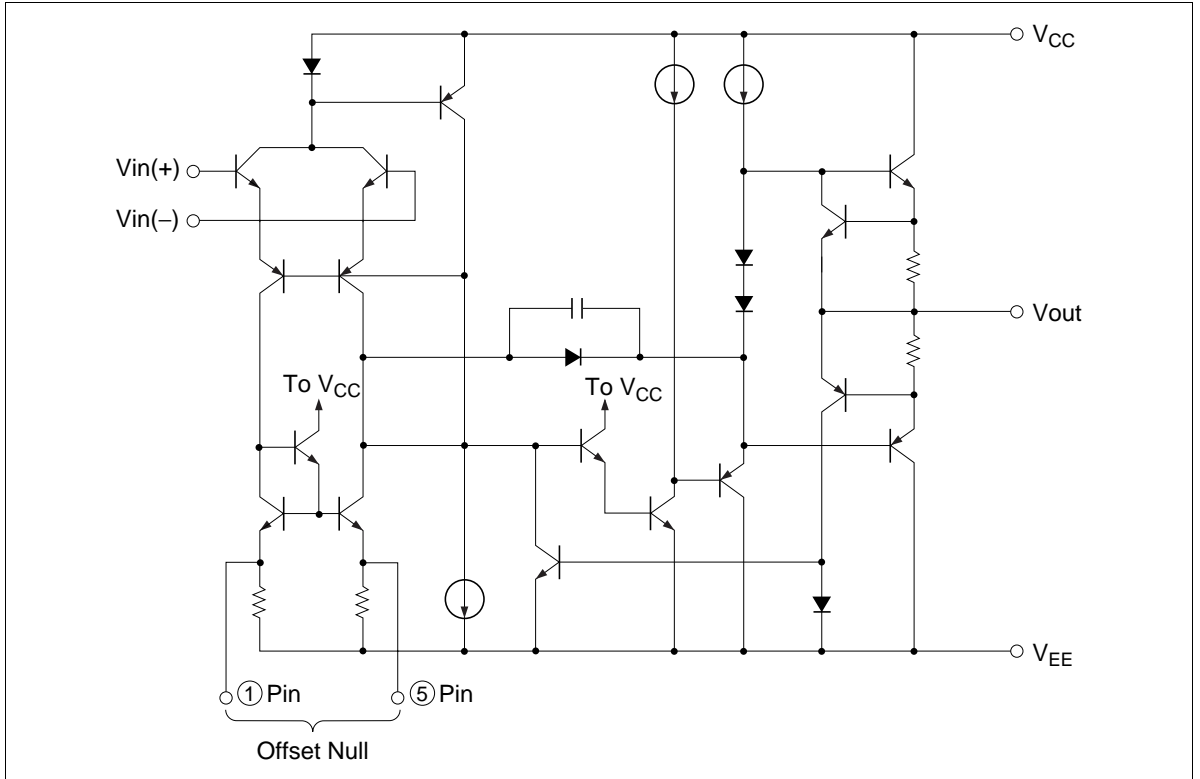

Absolute Maximum Ratings (Ta = 25°C)

Item	Symbol	Ratings		Unit
		HA17741PS	HA17741	
Power-supply voltage	V _{CC}	+18	+18	V
	V _{EE}	-18	-18	V
Input voltage	V _{in}	±15	±15	V
Differential input voltage	V _{in(diff)}	±30	±30	V
Allowable power dissipation	P _T	670 *	670 *	mW
Operating temperature	T _{opr}	-20 to +75	-20 to +75	°C
Storage temperature	T _{stg}	-55 to +125	-55 to +125	°C

Note: These are the allowable values up to Ta = 45°C. Derate by 8.3 mW/°C above that temperature.

Electrical Characteristics

Electrical Characteristics-1 ($V_{CC} = -V_{EE} = 15\text{ V}$, $T_a = 25^\circ\text{C}$)

Item	Symbol	Min	Typ	Max	Unit	Test Condition
Input offset voltage	V_{IO}	—	1.0	6.0	mV	$R_S \leq 10\text{ k}\Omega$
Input offset current	I_{IO}	—	18	200	nA	
Input bias current	I_{IB}	—	75	500	nA	
Power-supply rejection ratio	$\Delta V_{IO}/\Delta V_{CC}$	—	30	150	$\mu\text{V/V}$	$R_S \leq 10\text{ k}\Omega$
	$\Delta V_{IO}/\Delta V_{EE}$	—	30	150	$\mu\text{V/V}$	$R_S \leq 10\text{ k}\Omega$
Voltage gain	A_{VD}	86	106	—	dB	$R_L \geq 2\text{ k}\Omega$, $V_{out} = \pm 10\text{ V}$
Common-mode rejection ratio	CMR	70	90	—	dB	$R_S \leq 10\text{ k}\Omega$
Common-mode input voltage range	V_{CM}	± 12	± 13	—	V	$R_S \leq 10\text{ k}\Omega$
Maximum output voltage amplitude	V_{OP-P}	± 12	± 14	—	V	$R_L \geq 10\text{ k}\Omega$
		± 10	± 13	—	V	$R_L \geq 2\text{ k}\Omega$
Power dissipation	P_d	—	65	100	mW	No load
Slew rate	SR	—	1.0	—	V/ μs	$R_L \geq 2\text{ k}\Omega$
Rise time	t_r	—	0.3	—	μs	$V_{in} = 20\text{ mV}$, $R_L = 2\text{ k}\Omega$,
Overshoot	V_{over}	—	5.0	—	%	$C_L = 100\text{ pF}$
Input resistance	R_{in}	0.3	1.0	—	M Ω	

Electrical Characteristics-2 ($V_{CC} = -V_{EE} = 15\text{ V}$, $T_a = -20\text{ to }+75^\circ\text{C}$)

Item	Symbol	Min	Typ	Max	Unit	Test Condition
Input offset voltage	V_{IO}	—	—	9.0	mV	$R_S \leq 10\text{ k}\Omega$
Input offset current	I_{IO}	—	—	400	nA	
Input bias current	I_{IB}	—	—	1,100	nA	
Voltage gain	A_{VD}	80	—	—	dB	$R_L \geq 2\text{ k}\Omega$, $V_{out} = \pm 10\text{ V}$
Maximum output voltage amplitude	V_{OP-P}	± 10	—	—	V	$R_L \geq 2\text{ k}\Omega$

IC Operational Amplifier Application Examples

Multivibrator

A multivibrator is a square wave generator that uses an RC circuit charge/discharge operation to generate the waveform. Multivibrators are widely used as the square wave source in such applications as power supplies and electronic switches.

Multivibrators are classified into three types, astable multivibrators, which have no stable states, monostable multivibrators, which have one stable state, and bistable multivibrators, which have two stable states.

1. Astable Multivibrator

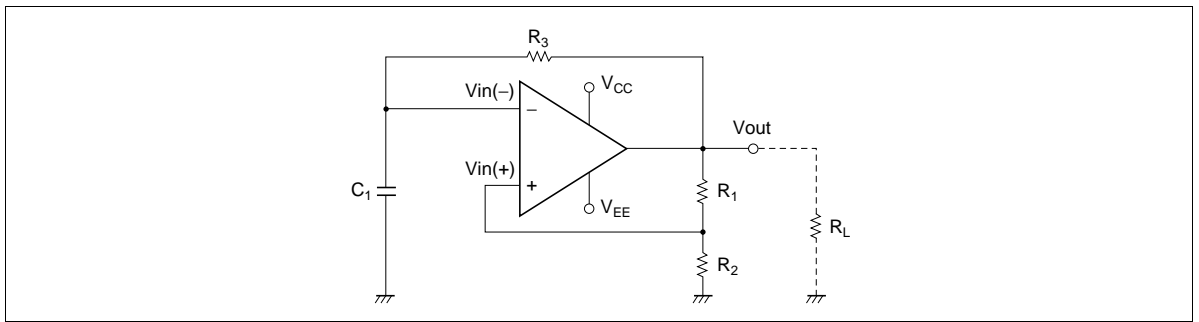

Figure 1 Astable Multivibrator Operating Circuit

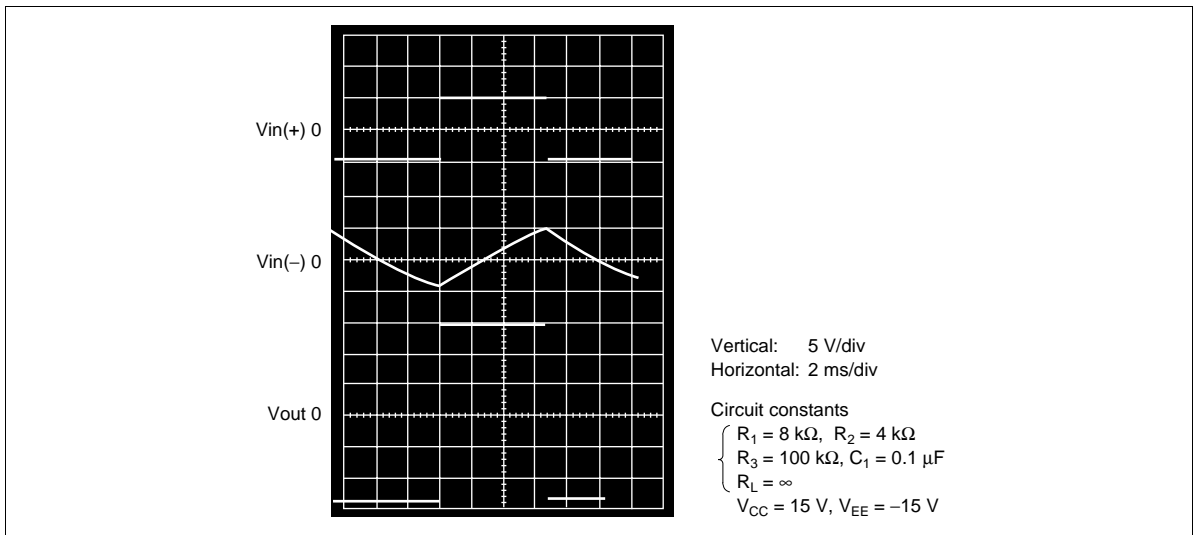

Figure 2 HA17741 Astable Multivibrator Operating Waveform

2. Monostable Multivibrator

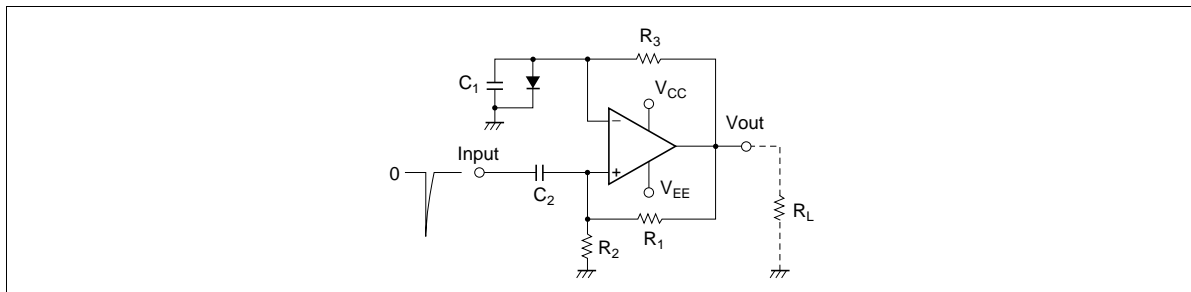

Figure 3 Monostable Multivibrator Operating Circuit

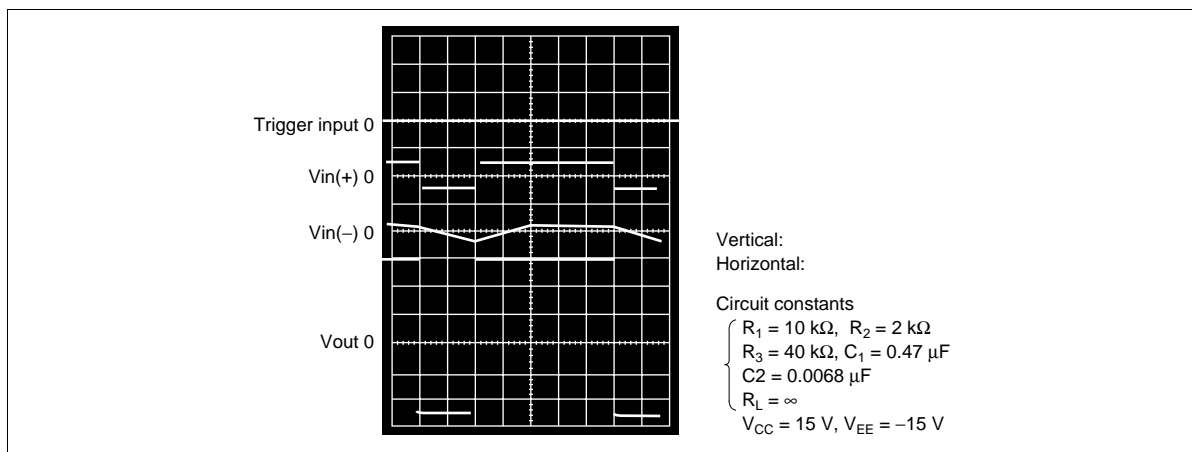

Figure 4 HA17741 Monostable Multivibrator Operating Waveform

3. Bistable Multivibrator

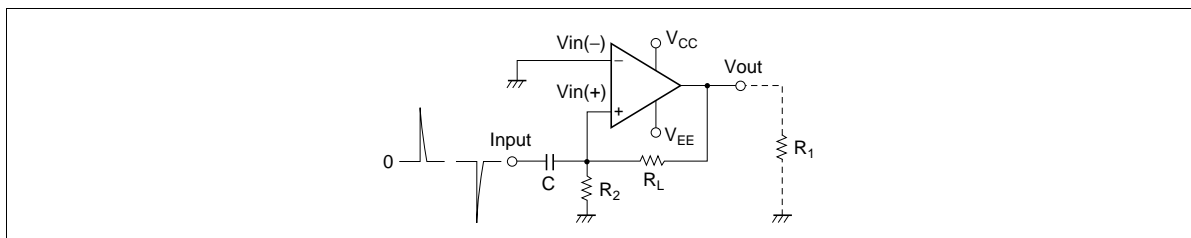

Figure 5 Bistable Multivibrator Operating Circuit

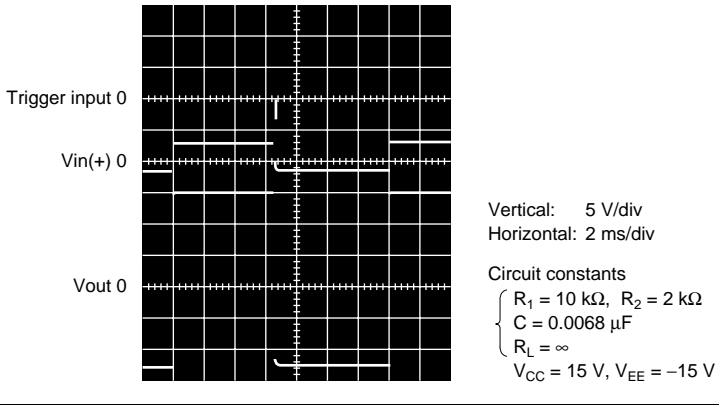

Figure 6 HA17741 Bistable Multivibrator Operating Waveform

Wien Bridge Sine Wave Oscillator

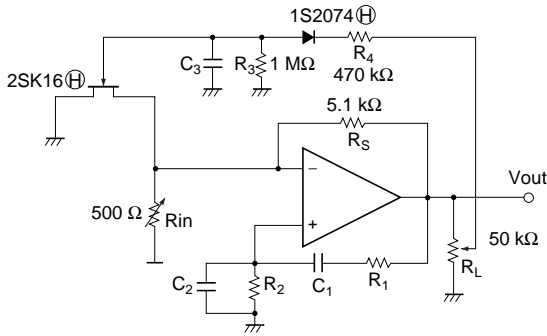

Figure 7 Wien Bridge Sine Wave Oscillator

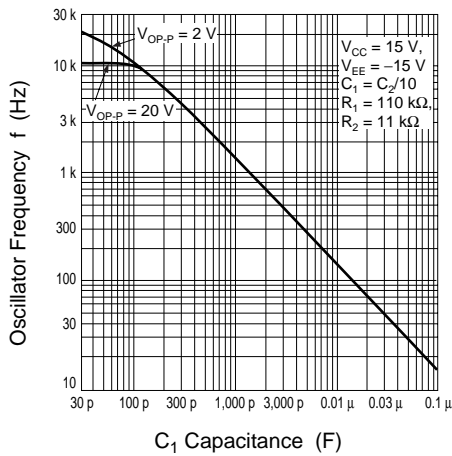

Figure 8 HA17741 Wien Bridge Sine Wave Oscillator f - C Characteristics

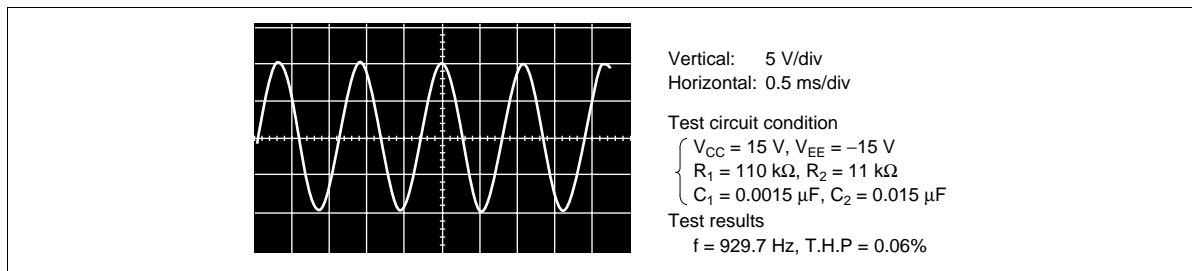

Figure 9 HA17741 Wien Bridge Sine Wave Oscillator Operating Waveform

Quadrature Oscillator

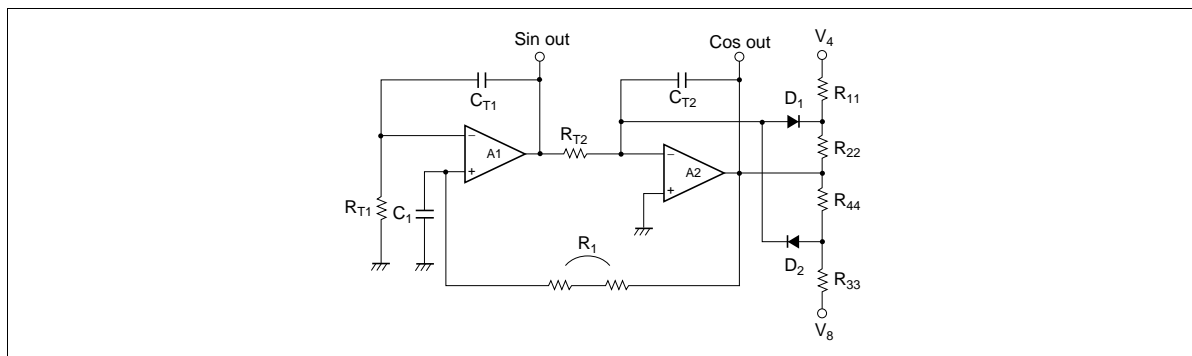

Figure 10 Quadrature Sine Wave Oscillator

Figure 10 shows the circuit diagram for a quadrature sine wave oscillator. This circuit consists of two integrators and a limiter circuit, and provides not only a sine wave output, but also a cosine output, that is, it also supplies the waveform delayed by 90°. The output amplitude is essentially determined by the limiter circuit.

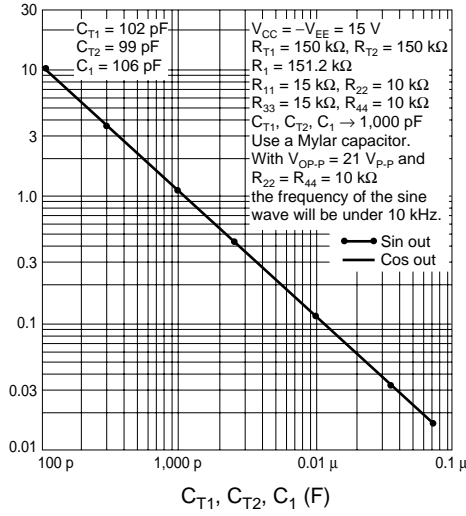
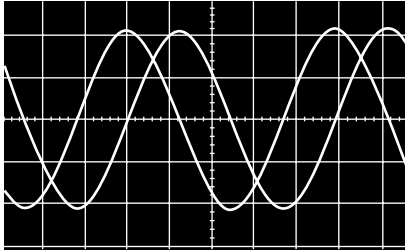

Figure 11 HA17741 Quadrature Sine Wave Oscillator

f-C_{T1}, C_{T2}, C₁ Characteristics



Vertical: 5 V/div
 Horizontal: 0.2 ms/div
 Circuit constants

$C_{T1} = 1000 \text{ pF (990)}, C_{T2} = 1000 \text{ pF (990)}$
 $R_{T1} = 150 \text{ k}\Omega, R_{T2} = 150 \text{ k}\Omega$
 $C_1 = 1000 \text{ pF (990)}, R_1 = 160 \text{ k}\Omega$
 $R_{11} = 15 \text{ k}\Omega, R_{22} = 10 \text{ k}\Omega$
 $R_{33} = 16 \text{ V}, R_{44} = 10 \text{ k}\Omega$
 $V_{CC} = 15 \text{ V}, V_{EE} = -15 \text{ V}$

Figure 12 Sine and Cosine Output Waveforms

Triangular Wave Generator

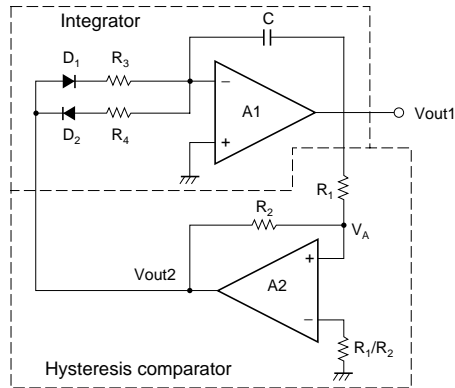

Figure 13 Triangular Wave Generator Operating Circuit

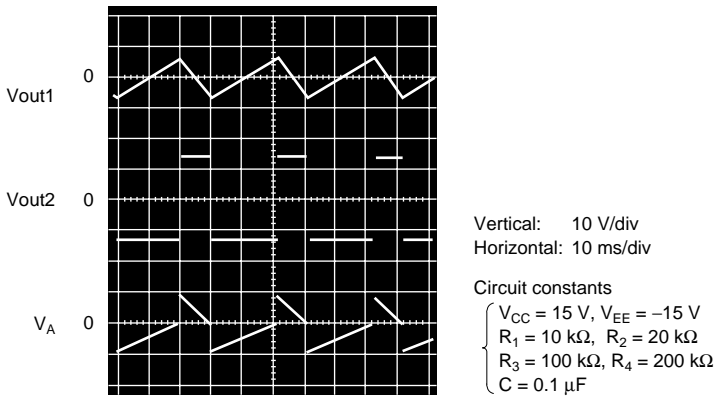

Figure 14 HA17741 Triangular Wave Generator Operating Waveform

Sawtooth Waveform Generator

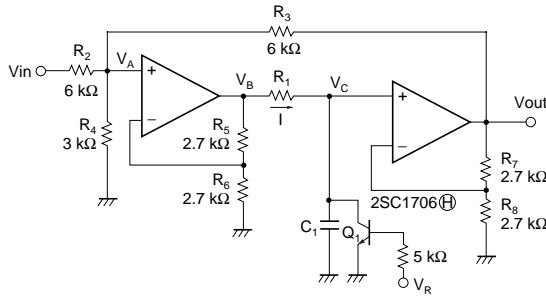

Figure 15 Sawtooth Waveform Generator

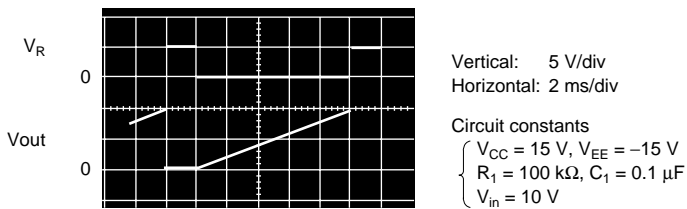
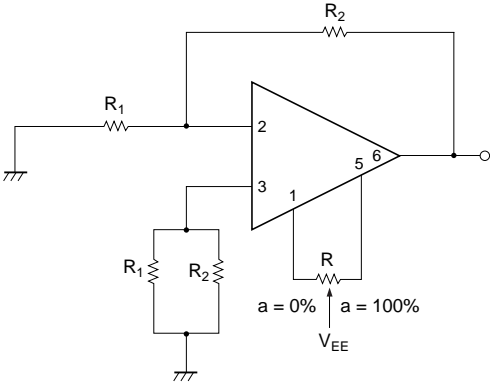

Figure 16 HA17741 Sawtooth Waveform Generator Operating Waveform

Characteristic Curves

Voltage Offset Adjustment Circuit



Input Offset Current vs. Power-Supply Voltage Characteristics

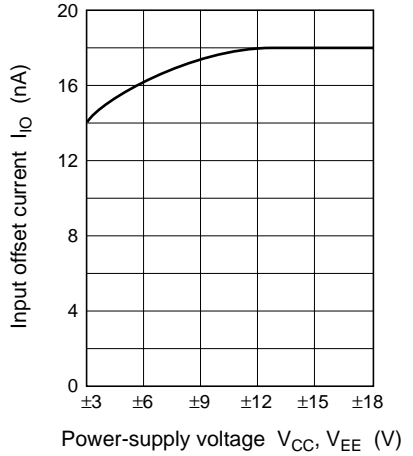

Power Dissipation vs. Power-Supply Voltage Characteristics

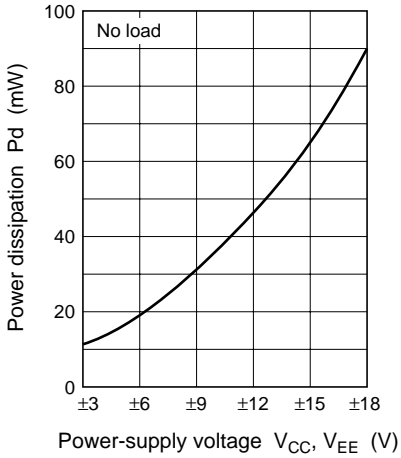

Voltage Gain vs. Power-Supply Voltage Characteristics

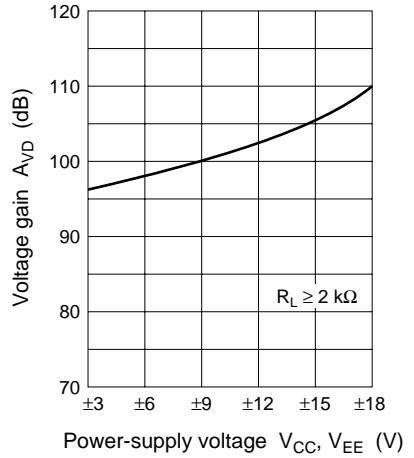

Maximum Output Voltage Amplitude vs. Power-Supply Voltage Characteristics

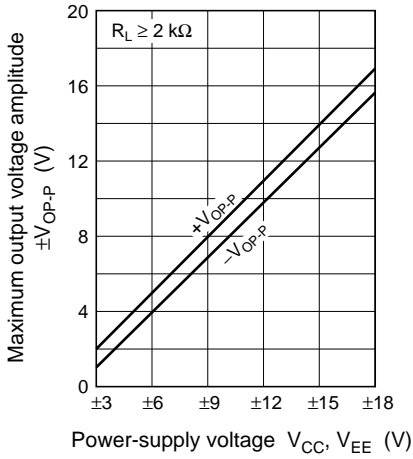

Input Offset Voltage vs. Ambient Temperature Characteristics

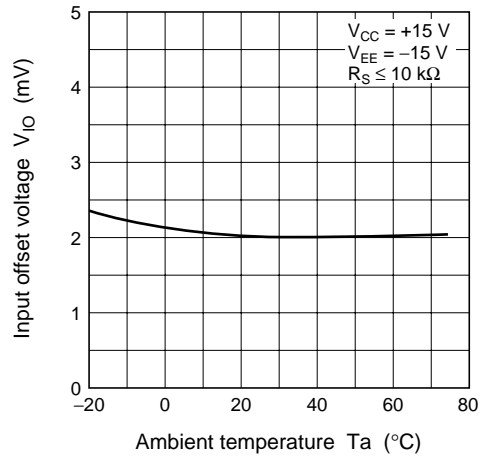

Input Offset Current vs. Ambient Temperature Characteristics

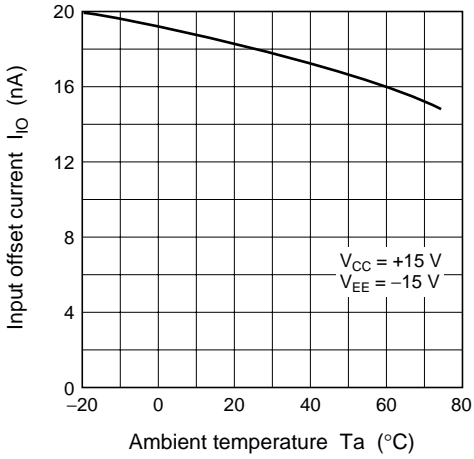

Input Bias Current vs. Ambient Temperature Characteristics

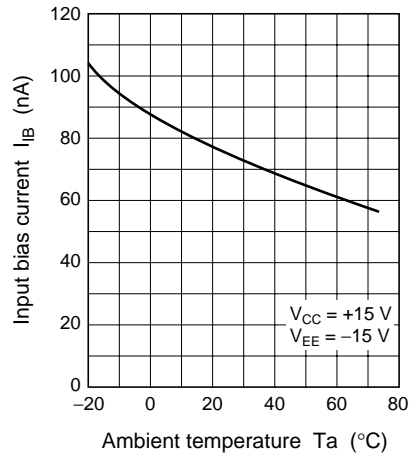

Power Dissipation vs. Ambient Temperature Characteristics

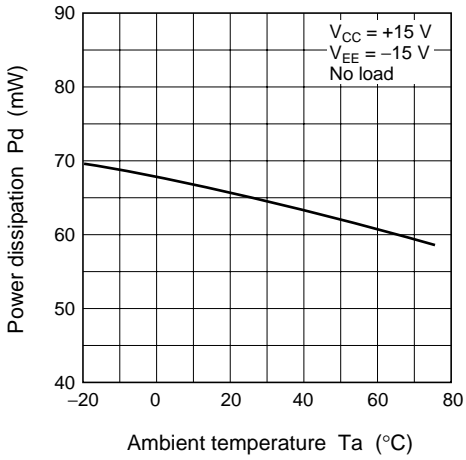

Voltage Gain vs. Ambient Temperature Characteristics

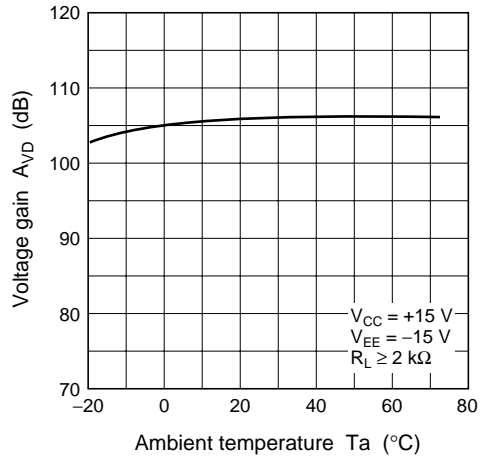

Maximum Output Voltage Amplitude vs. Ambient Temperature Characteristics

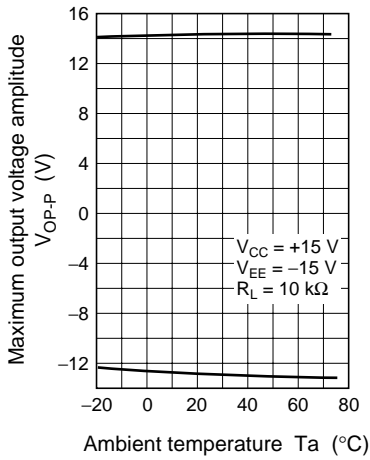

Output Shorted Current vs. Ambient Temperature Characteristics

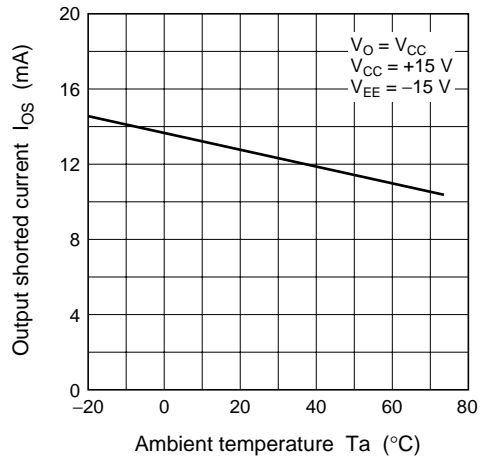

Maximum Output Voltage Amplitude vs. Load Resistance Characteristics

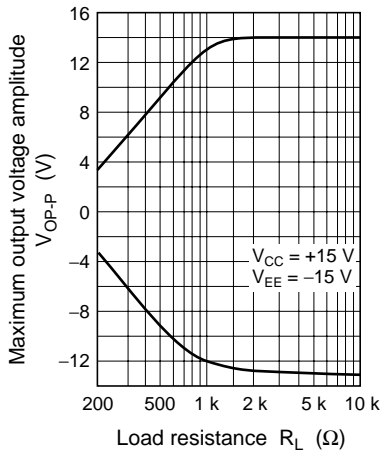

Offset Adjustment Characteristics

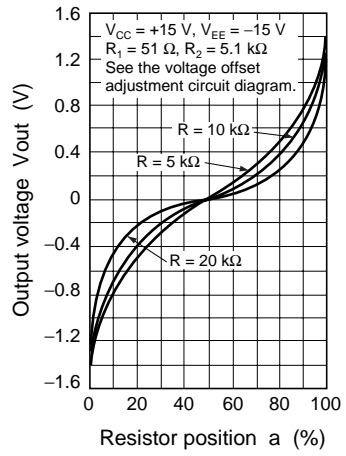

Maximum Output Voltage Amplitude vs. Frequency Characteristics

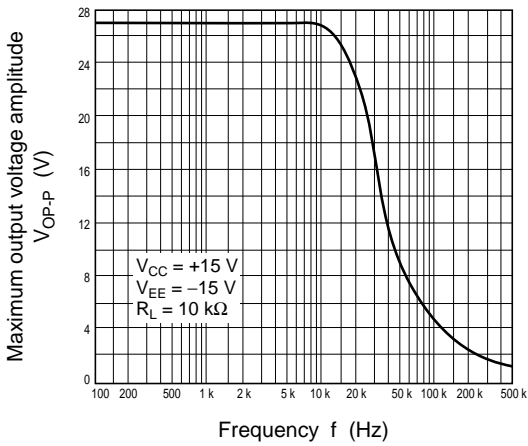

Input Resistance vs. Frequency Characteristics

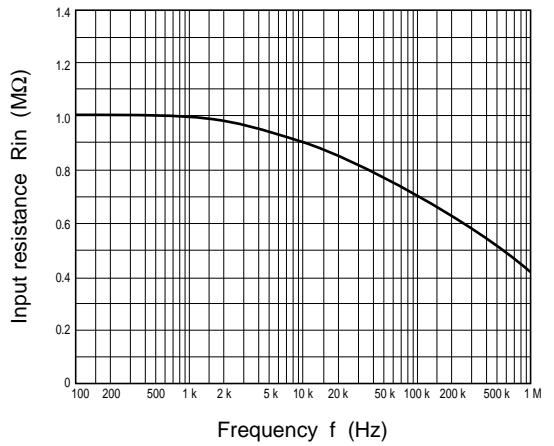

Phase vs. Frequency Characteristics

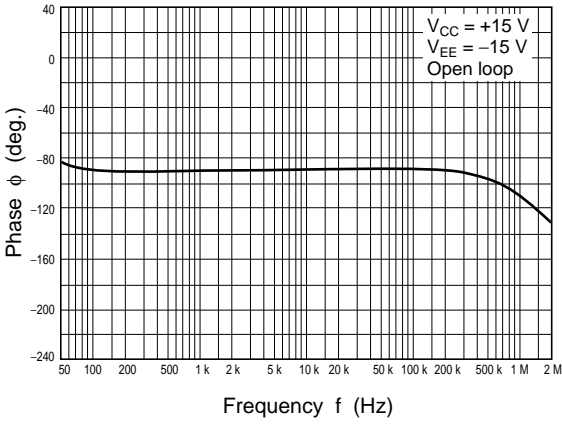

Voltage Gain vs Frequency Characteristics

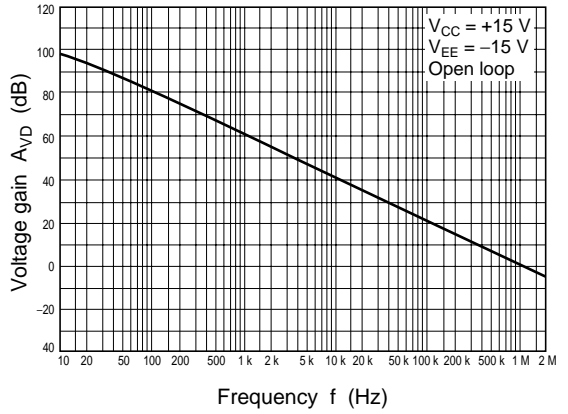

Voltage Gain and Phase vs. Frequency Characteristics (1)

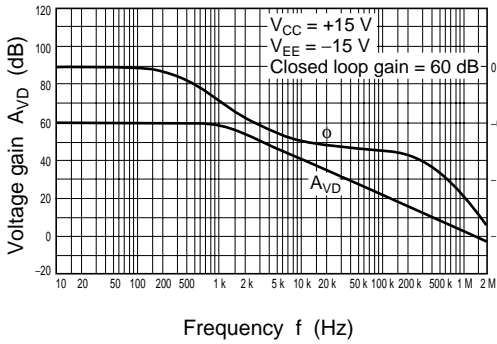

Voltage Gain and Phase vs. Frequency Characteristics (2)

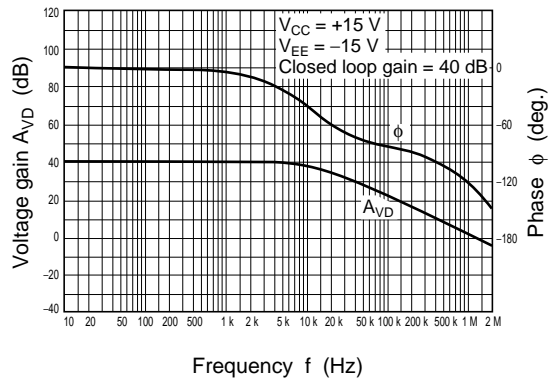

Voltage Gain and Phase vs. Frequency Characteristics (3)

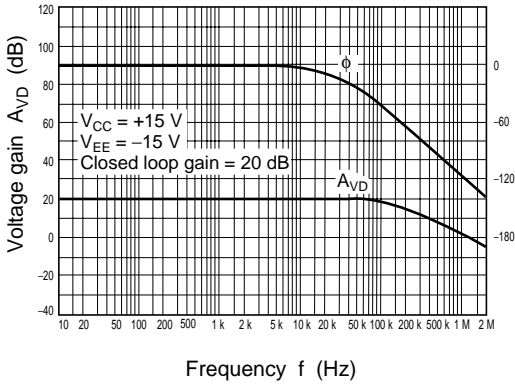

Voltage Gain and Phase vs. Frequency Characteristics (4)

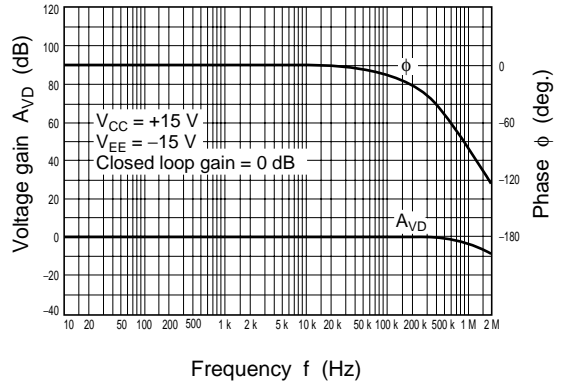

Impulse Response Characteristics Test Circuit

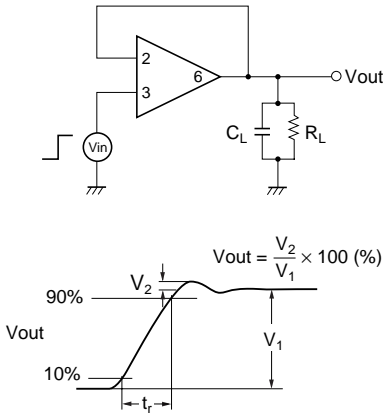

Rise time vs. Power-Supply Voltage Characteristics

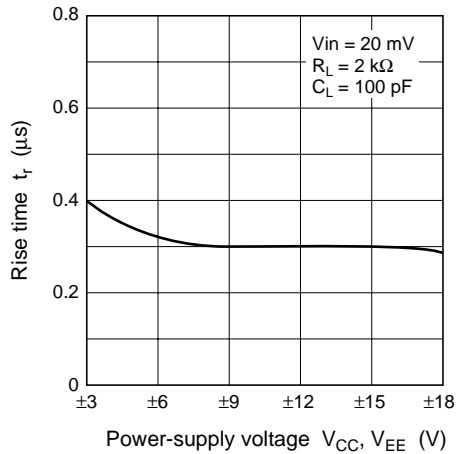

**Overshoot vs.
Power-Supply Voltage Characteristics**

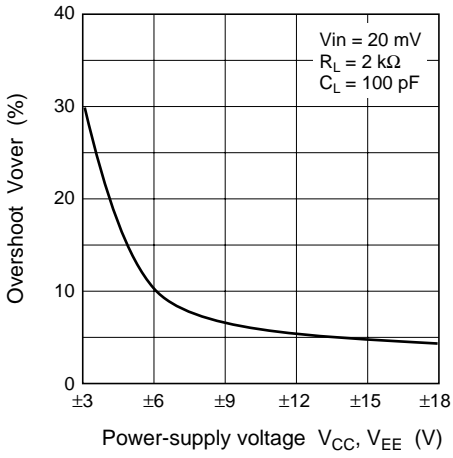

**Impulse Response
Characteristics**

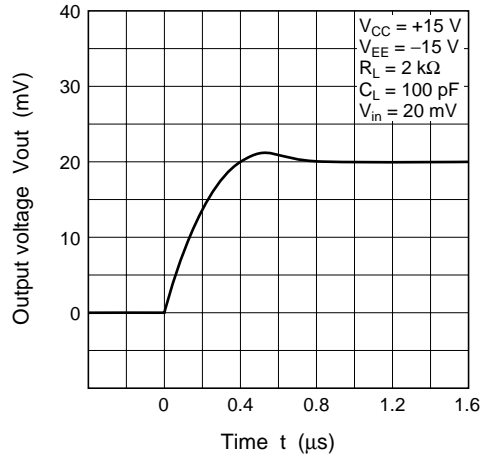

Package Dimensions

Unit: mm

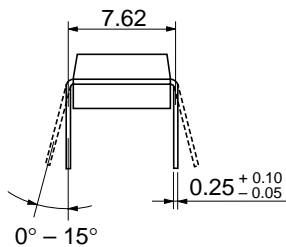
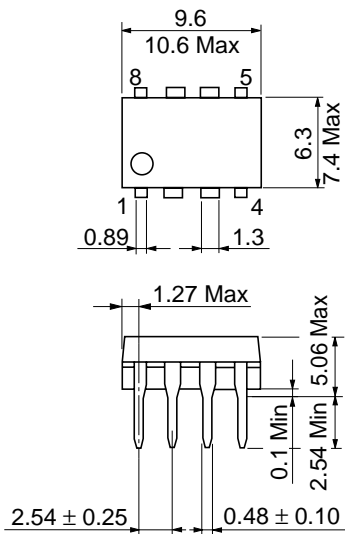

Hitachi Code	DP-8
JEDEC	Conforms
EIAJ	Conforms
Mass (reference value)	0.54 g

Cautions

1. Hitachi neither warrants nor grants licenses of any rights of Hitachi's or any third party's patent, copyright, trademark, or other intellectual property rights for information contained in this document. Hitachi bears no responsibility for problems that may arise with third party's rights, including intellectual property rights, in connection with use of the information contained in this document.
2. Products and product specifications may be subject to change without notice. Confirm that you have received the latest product standards or specifications before final design, purchase or use.
3. Hitachi makes every attempt to ensure that its products are of high quality and reliability. However, contact Hitachi's sales office before using the product in an application that demands especially high quality and reliability or where its failure or malfunction may directly threaten human life or cause risk of bodily injury, such as aerospace, aeronautics, nuclear power, combustion control, transportation, traffic, safety equipment or medical equipment for life support.
4. Design your application so that the product is used within the ranges guaranteed by Hitachi particularly for maximum rating, operating supply voltage range, heat radiation characteristics, installation conditions and other characteristics. Hitachi bears no responsibility for failure or damage when used beyond the guaranteed ranges. Even within the guaranteed ranges, consider normally foreseeable failure rates or failure modes in semiconductor devices and employ systemic measures such as fail-safes, so that the equipment incorporating Hitachi product does not cause bodily injury, fire or other consequential damage due to operation of the Hitachi product.
5. This product is not designed to be radiation resistant.
6. No one is permitted to reproduce or duplicate, in any form, the whole or part of this document without written approval from Hitachi.
7. Contact Hitachi's sales office for any questions regarding this document or Hitachi semiconductor products.

HITACHI

Hitachi, Ltd.

Semiconductor & Integrated Circuits.

Nippon Bldg., 2-6-2, Ohite-machi, Chiyoda-ku, Tokyo 100-0004, Japan

Tel: Tokyo (03) 3270-2111 Fax: (03) 3270-5109

URL NorthAmerica : <http://semiconductor.hitachi.com/>
 Europe : <http://www.hitachi-eu.com/hel/ecg>
 Asia (Singapore) : <http://www.has.hitachi.com.sg/grp3/sicd/index.htm>
 Asia (Taiwan) : http://www.hitachi.com.tw/E/Product/SICD_Frame.htm
 Asia (HongKong) : <http://www.hitachi.com.hk/eng/bo/grp3/index.htm>
 Japan : <http://www.hitachi.co.jp/Sicd/indx.htm>

For further information write to:

Hitachi Semiconductor
 (America) Inc.
 179 East Tasman Drive,
 San Jose, CA 95134
 Tel: <1> (408) 433-1990
 Fax: <1> (408) 433-0223

Hitachi Europe GmbH
 Electronic components Group
 Dornacher Straße 3
 D-85622 Feldkirchen, Munich
 Germany
 Tel: <49> (89) 9 9180-0
 Fax: <49> (89) 9 29 30 00

Hitachi Europe Ltd.
 Electronic Components Group.
 Whitebrook Park
 Lower Cookham Road
 Maidenhead
 Berkshire SL6 8YA, United Kingdom
 Tel: <44> (1628) 585000
 Fax: <44> (1628) 778322

Hitachi Asia Pte. Ltd.
 16 Collyer Quay #20-00
 Hitachi Tower
 Singapore 049318
 Tel: 535-2100
 Fax: 535-1533

Hitachi Asia Ltd.
 Taipei Branch Office
 3F, Hung Kuo Building, No.167,
 Tun-Hwa North Road, Taipei (105)
 Tel: <886> (2) 2718-3666
 Fax: <886> (2) 2718-8180

Hitachi Asia (Hong Kong) Ltd.
 Group III (Electronic Components)
 7/F., North Tower, World Finance Centre,
 Harbour City, Canton Road, Tsim Sha Tsui,
 Kowloon, Hong Kong
 Tel: <852> (2) 735 9218
 Fax: <852> (2) 730 0281
 Telex: 40815 HITEC HX

Copyright ' Hitachi, Ltd., 1998. All rights reserved. Printed in Japan.

HITACHI

This datasheet has been download from:

www.datasheetcatalog.com

Datasheets for electronics components.